

United States of America
Department of Transportation — Federal Aviation Administration
Supplemental Type Certificate

Number SA4-302

This certificate, issued to ACS Products Co., Inc.

*certifies that the change in the type design for the following product with the limitations and conditions therefor as specified hereon meets the airworthiness requirements of Part * of the **

Regulations. * Certification Basis is listed on attached FAA Approved Master Eligibility List No. 4302.

Original Product — Type Certificate Number:

Make: Listed on attached FAA Approved Master Eligibility List No. 4302

Model:

Description of Type Design Change:

Installation of BN-1 Spinner in accordance with Aircraft Spruce and Specialty Company Drawing No. 10002.

Detail Parts Manufactured in accordance with Aircraft Spruce and Specialty Co. Drawing No. 10001.

Limitations and Conditions: The approval of this change in type design applies basically to Models listed on attached FAA Approved Master Eligibility List No. 4302 only. This approval should not be extended to other aircraft of this model on which other previously approved modifications are incorporated unless it is determined by the installer that the interrelationship between this change and any of those other previously approved modifications will introduce no adverse effect upon the airworthiness of that aircraft.

This certificate and the supporting data which is the basis for approval shall remain in effect until surrendered, suspended, revoked, or a termination date is otherwise established by the Administrator of the Federal Aviation Administration.

Date of application: October 9, 1957

Date issued: February 27, 1974, August 15, 1985,
October 30, 1985

Date of issuance: October 14, 1957

Date amended: November 30, 1965, March 14, 1966



By direction of the Administrator

Marvin F. Rammeberg
for CHARLES I. BLOMER, ^(Signature) Manager

Western Aircraft Certification Office

(Title)

Any alteration of this certificate is punishable by a fine of not exceeding \$1,000, or imprisonment not exceeding 3 years, or both.

ACS PRODUCTS CO.

Page 1 of 3

P.O. Box 152 (Mail) • 1585 Copper Drive • Lake Havasu City, AZ 86403-0008
Phone: (602) 855-8613 • FAX: (602) 855-2104

MASTER AIRCRAFT ELIGIBILITY LIST NO. 4302

AIRCRAFT ELIGIBLE FOR INSTALLATION OF MODEL BN-1 PROPELLER SPINNER

(STC NO. SA4-302)

FAA APPROVED

Original Issue Date: 11/30/65
Revision No. 1: 10/4/90

OCT 15 1990

LOS ANGELES,
AIRCRAFT CERTIFICATION OFFICE
INITIALS: CMV-143L

A log-book entry should be made by the installing mechanic stating the spinner was installed according to the Model BN-1 installation instructions.

The weight of the BN-1 Spinner installation is negligible by a 1957 decision of the Aircraft Engineering Division, Region 4, Los Angeles, and a Form #337, covering weight and balance change is not necessary.

Additional aircraft which are eligible for installation of this model spinner are added to the Master Eligibility List by means of a conformity inspection by the local FAA Inspector. Before the spinner is installed on an aircraft not on the Master List, ACS Products Co. should be contacted to ascertain that the aircraft model will be eligible. The installation procedure furnished with the spinner will be used to check conformity and the FAA Inspector will fill out Form 8100-1. The completed Form 8100-1 will be mailed direct to ACS Products Co. for processing.

Item No.	Aircraft Make and Model No.	Original T.C. No.	Certification Basis
1.	AERONCA 50-TC, 60-TF, 65-TF, 50-TL, 65-TL, 65-TAC, 65-TAF, 65-TAL, Y0-58, 65-TC	728	CAR-4a
2.	AERONCA (TRYTEK) KCA, 50-C, 65-C, 65-CA, S-50-C, S-65-C, S-65-CA	675	Aero Bulletin 7-A
3.	AERONCA (CHAMPION) 7AC, S7AC, 7BCM, 7CCM, S7CCM, 7DC, S7DC, 7EC, S7EC, 7FC	759	CAR-4a
4.	AERONCA 11AC, S11AC, 11BC, S11BC	761	CAR-4a
5.	AERONCA 15AC, S15AC	802	CAR-3
6.	BELLANCA 14-13, 14-13-2, 14-13-3, 14-13-3W	773	CAR-4a

MASTER AIRCRAFT ELIGIBILITY LIST NO. 4302, REVISION NO. 1, CONTINUED

Item No.	Aircraft Make and Model No.	Original T.C. No.	Certification Basis
28.	PIPER PA-17	805	CAR-3
29.	PIPER PA-18, PA-18A, PA-18S, PA-18-105, PA-18S-125, PA-18-125, PA-18AS-125, PA-18-135, PA-18A-135, PA-18AS-135, PA-18S-135, PA-18-150, PA-18AS-150, PA-18S-150, PA-19, PA-19S	1A2	CAR-3
30.	PIPER PA-20, PA-20S, PA-20S-115, PA-20-115, PA-20S-135, PA-20-135	1A4	CAR-3
31.	PIPER PA-22, PA-22-135, PA-22S-135, PA-22-150, PA-22S-150, PA-22-160, PA-22S-160	1A6	CAR-3
32.	PORTERFIELD (NORTHWESTERN AERONAUTICAL) CP-55, CP-65, FP-65, LP-65	720	CAR-4a
33.	STINSON HW-75, 10	709	CAR-4a
34.	STINSON (UNIVERSAL) 108, 108-1, 108-2, 108-3	767	CAR-3
35.	TAYLORCRAFT DC-65, DC0-65, DL-65	746	CAR-4a
36.	TAYLORCRAFT BL, BLS, BL-65, BL12-65, BLS12-65, BLS-65	700	CAR-4a
37.	TAYLORCRAFT (UNIVERSAL) BC, BCS, BC-65, BCS-65, BC12-65, BCS12-65, BC12-D, BCS12-D, BC12-D1, BCS12-D1, BC12D-85, BC12D-4-85, BCS12D-4-85	696	CAR-4a

-END-

FAA APPROVED

OCT 15 1990

LOS ANGELES,
AIRCRAFT CERTIFICATION OFFICE
INITIALS: CMV-143L

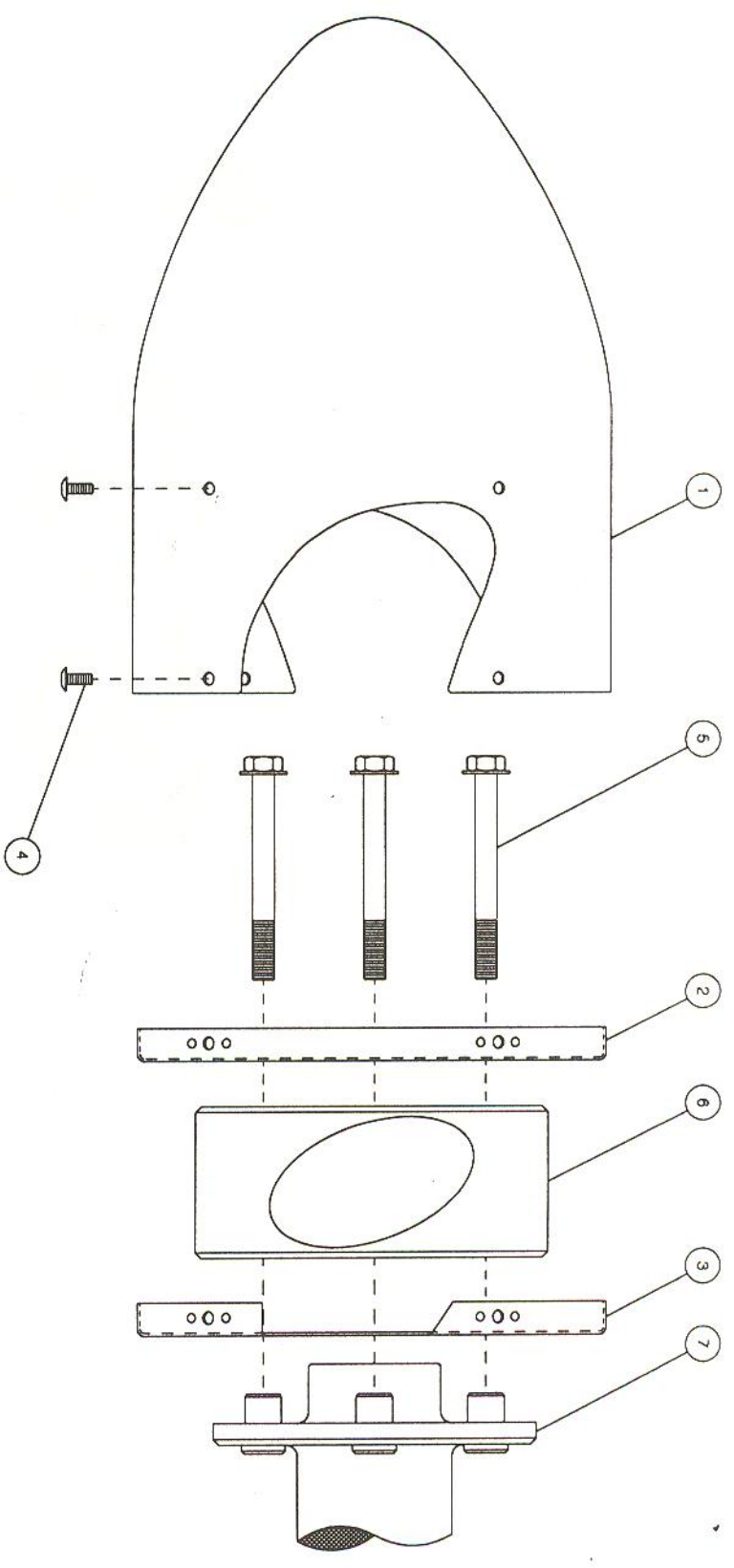

NOTES

- 1) DOME MUST ALWAYS BE INSTALLED USING TWO BULKHEADS.
- 2) INSTALL PROPELLER, TOP HOLE MOUNTING BOLTS, AND SAFETY WIRE BOLTS HEADS PER MANUFACTURER'S INSTRUCTIONS.
- 3) ITEM 4 SCREWS DO NOT REQUIRE A THREAD LOCKING COMPOUND ON ASSEMBLY. THE NUTPLATES HAVE A SELF-LOCKING THREAD CONFIGURATION.
- 4) THE LETTER 'M' IS STAMPED NEXT TO A NUTPLATE ON EACH OF THE BULKHEADS AND NEXT TO A LOWER MOUNTING HOLE ON THE INSIDE OF THE DOME. THE 'M' HOLES SHOULD ALL BE IN ALIGNMENT ON ASSEMBLY.

ITEM	QTY	PART NUMBER	DESCRIPTION
7	1		PROPELLER SHAFT END
6	1		PROPELLER
5	6		PROPELLER MOUNTING BOLTS
4	12	AN528-1022R8	MACHINE SCREW - CARBON STEEL, CADMIUM PLATED
3	3	SEN-BN1-FBH	REAR BULKHEAD - ALUMINUM
2	2	SEN-BN1-FBH	FRONT BULKHEAD - ALUMINUM
1	1	SEN-BN1-DOME	DOME - ALUMINUM

NAME	DATE	REV	SCALE
ACS PRODUCTS CO.	03-22-01	1	NA
LAKE HAVASU CITY, ARIZONA	DATE	REV	REV
	03-22-01	1	NC
			1 OF 1

ASSEMBLY VIEW -
SENSENICH BN1 SPINNER KIT ASSEMBLY

DRAWING NUMBER
SEN-BN1