



SENSENICH THREE BLADE COMPOSITE AIRCRAFT PROPELLER INSTALLATION AND OPERATION INSTRUCTIONS FOR UL POWER ENGINES

DOC#: 3E0 Installation_Instructions_Rev0 6/16/17

ATTENTION

Failure to follow these instructions will void all warranties, expressed and implied. Mounting difficulties, vibration, and/or failure can result with improper assembly of the propeller blades and hub parts.

CAUTION

Rotating propellers are particularly dangerous. Extreme caution must be exercised to prevent severe bodily injury or death.

TABLE OF CONTENTS

Propeller Packing List – 3E0	2
FIG 1. Propeller Assembly	2
Propeller Description and Features	3
Required Tools	3
Propeller Installation	4
FIG 2. Nord-Lock Lock Washer	4
FIG 3. Pitch Setting Gage	4
Re-pitching	5
Propeller Removal	6
Propeller Performance	6
Pitch Notes and Limitations	6
Tachometer Inspection	7
TABLE 1: Installation Torque for Mounting and Clamping Hardware	7
TABLE 2: Approved Engine / Propeller Combinations and Limitations	7
Instructions for Continued Airworthiness (ICA)	8
Inspections	9
Repairs	11
FIG 4. Minor Hub Repair Limits	12
Limited Warranty	12
Propeller Logbook	13

PACKING LIST FOR 3E0

INSTALLATION WITH CONTINENTAL THREADED FLANGE BUSHINGS

Item	Description	Qty
1	Hub Mount Half	1
2	Inner Mount Bolts 3/8"-24 x 1.75"	3
3	Composite Blades	3
4	Hub Cover Half	1

Item	Description	Qty
5	Clamp Bolts 3/8"-24 x 1.75"	6
6	Locking Washer NL3/8"SP Nord-lock	12
7	Outer Mount Bolt 3/8"-24 x 4.50"	3

FIGURE 1. PROPELLER ASSEMBLY

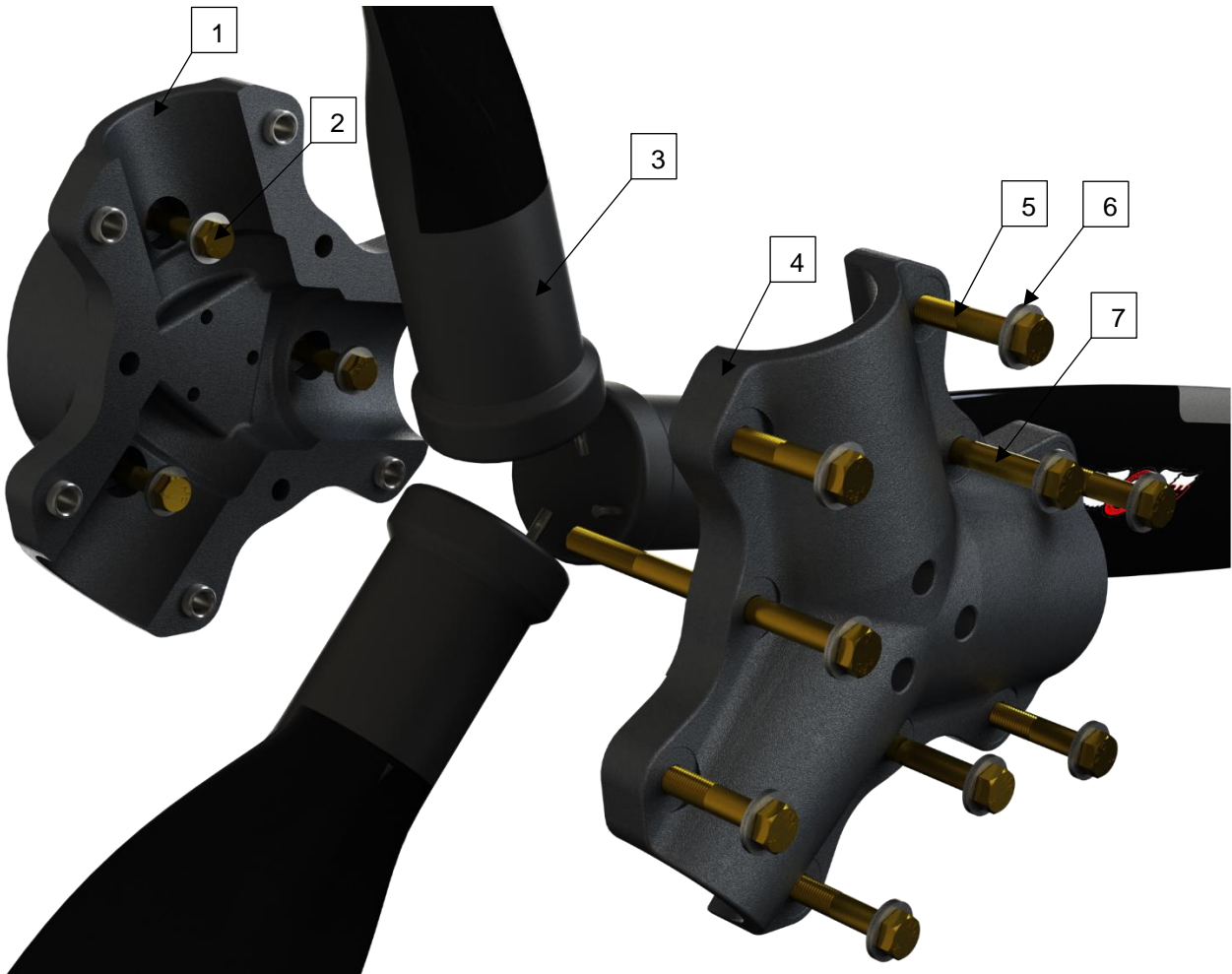

OVERALL DESCRIPTION OF THE PROPELLER AND ITS FEATURES:

Your Sensenich composite propeller was manufactured using aerospace quality materials and processes. Propeller balance was verified before shipment from the factory.

The blades were manufactured by internal pressure molding, utilizing the latest technology in carbon fiber and glass prepreg materials in a high temperature internal pressure molding process. This yields a hollow, low inertia propeller with superior performance and durability.

The propeller finish provides UV and environmental protection. Rain and sand protection is provided by metal erosion shields on the blade leading edges. The erosion shields are co-cured with the blade prepreg, providing a smoother finish and a superior bond.

Sensenich's Pitch Gage/Hub system allows its users to set a broad range of pitches, using the system's preset gages when making adjustments. The various gages provide numerous settings of pitch change affording maximum performance within an efficient aerodynamic envelope. The blade pins contact the pitch setting gage providing a very precise blade angle and therefore eliminating the need for a blade angle measurement device.

REQUIRED TOOLS

Torque Wrench
Variable Socket Sizes

Note: Certain aircraft manufacturers limit total pitch range to comply with aircraft design regulations.

PROPELLER INSTALLATION

1. Ensure the aircraft magneto switch is in the "OFF" position and that both magnetos are grounded any time the propeller is handled. Chock the aircraft wheels to prevent movement. Clean dirt and oil residue from the engine flange. Refer to **Figure 1** for views of the two piece hub, blade, and pitch setting gauge.
 2. Place spacer (if required), rear spinner bulkhead (if used) and the hub mount, as shown in **Figure 1**, on the propeller mounting flange. The hub must sit flush on the mounting flange.
- Note:**
Bolt breakage *WILL* occur if there is a gap between the propeller hub, the spacer (if required), and the engine flange.
3. Refer to **Figure 1** for views of the two-piece hub, blade, and pitch setting gauge. Using the three Nord-Lock washers and three short mount bolts, secure the hub mount, rear spinner bulkhead (if used), and the spacer (if required) to the engine flange. Using a calibrated torque wrench, torque the 3 mounting bolts evenly using an alternating pattern. Tighten the bolts in several increments up to full torque, such as 50%, 75%, and full torque. See **Table 1** or hub decal for bolt torque values.
 4. Each blade airfoil has a round side and a flat side. Insert the blades into the hub mount half with the round side facing away from the aircraft.
 5. Place the Nord-Lock washers on each of the 6 outboard clamping bolts and insert bolts into the bolt holes at the outboard end of each hub barrel.

NOTE: Each Nord-lock washer works in pairs with the "ramped" sides facing each other. See Figure 2.

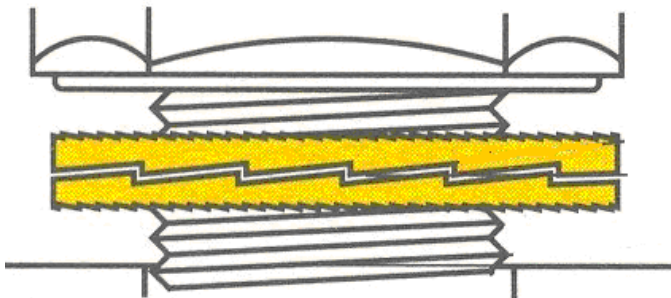

FIGURE 2. NORD-LOCK LOCK WASHER

6. Hand tighten the clamping bolts. The blades should rotate in the hub but they should not be loose. If the blades cannot rotate in the hub, loosen the clamping bolts slightly.
7. Rotate each blade towards high pitch, ensuring that the pitch pin on the blade shank is not obstructing the receiving hole for the pitch setting gauge. Rotate the blade's leading edge away from the work surface to produce high pitch, or more "bite".
8. Insert the pitch setting gauge through the clearance hole in the hub cover half and into the receiving hole in the hub mount half. See **Figure 3**. Be sure to use the nominal setting of 4 to start. The pitch setting # indicates relative pitch; pitch 5 is higher pitch than pitch setting 4, etc...
9. With the pitch setting gauge in place, rotate the blade to low pitch until the pitch pin is touching the pitch setting gauge. Snug the two clamping bolts for the corresponding blade barrel to prevent unwanted rotation of the blade.

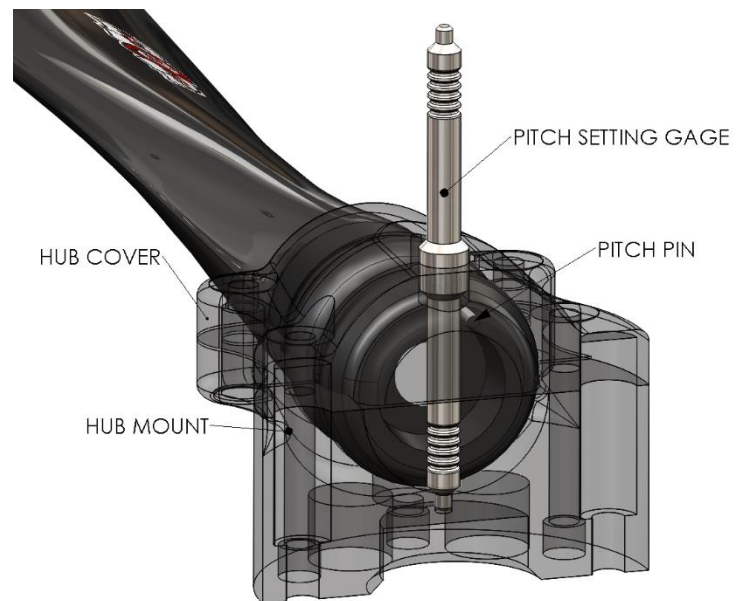

FIGURE 3. PITCH SETTING GAGE DETAIL

10. Remove the pitch setting gauge from the hub.
11. Repeat steps 8-10 for each blade.
12. Using a calibrated torque wrench, torque the three mount bolts and six clamp bolts in a criss-cross pattern. Tighten the bolts in several increments up to full torque, such as 50%, 75%, and full torque. See **Table 1** or hub decal for bolt torque values.

13. Check the propeller blades for track. The blades should track within 3/16" of each other at the tip. Note that setting the pitch accurately is more important than track from blade to blade.

BEFORE ENGINE START:

Make sure the pitch setting gauges have been removed from the hub and check engine compartment for tools before starting the engine.

Tachometer accuracy is critical for safe operation of the propeller. Refer to the TACHOMETER INSPECTION section for important considerations.

14. Start engine and run propeller for approximately 5 minutes at 50% of the desired RPM. After such time, shut down the engine and check all nine bolts to see if they have lost torque. It is a normal occurrence for the bolts to lose a small amount torque due to seating of the blades. If this has occurred, tighten again to the proper torque.

Note: This torque value should be checked after the first 5 hours of operation and at least once a year thereafter.

15. See **Table 2** for **Engine / Propeller Combinations and Limitations.**

CAUTION: YOU SHOULD NEVER EXCEED THE MAXIMUM RPM RATING FOR YOUR ENGINE.

With the brakes on, run up the propeller to check your pitch for desired maximum RPM. Remember, the propeller will pick up RPM at full throttle/level flight. If your RPM's are too low, adjust the blades to a lower pitch setting. If the RPM's are too high, adjust the blades to a higher pitch setting using the procedure below. Check your aircraft and/or engine manual for recommended static rpm. If you are not seeing your correct static RPM, be certain the tach was properly calibrated. You may contact Sensenich to purchase a slightly lower or higher pitch setting gauge if you feel this is the problem due to your density altitude.

CAUTION: YOU SHOULD NEVER MASK A POSSIBLE ENGINE PROBLEM WITH A PITCH CHANGE. If you are unsure, please contact the factory.

16. Install spinner front bulkhead (not used in some spinners) and spinner dome (if used). Refer to **Sensenich Supplemental Instructions for Composite Spinners.**

NOTE: Ensure there is adequate clearance between the spinner dome cutouts and the propeller blades and hub. Inadequate clearance may result in the spinner dome wearing into the blade or hub. The amount of clearance depends on engine type and spinner construction, but a minimum of 1/8" clearance is recommended.

REPITCHING

1. Ensure that the aircraft magneto switch is in the "OFF" position and that both magnetos are grounded any time the propeller is handled.
2. Loosen the clamp and mount bolts slightly.

NOTE: The Nord-Lock washers may click loudly when loosened; this is normal. New Nord-Lock washers are assembled with rubber adhesive, which will fall apart after first use.

3. Rotate each blade's leading edge towards high pitch to ensure that the pitch pin on the blade shank is not obstructing the receiving hole for the pitch setting gauge.
4. Insert the desired pitch setting gauge thru the clearance hole in the hub cover half and into receiving hole in the hub mount half. See **Figure 3.**
5. With the pitch setting gauge in place, rotate the blade to low pitch until the pitch pin is touching the pitch setting gauge. Be sure not force the blade onto pitch setting gauge as you may bend the pin.
6. Tighten the nine bolts to prevent unwanted rotation of the blade.
7. Remove the pitch setting gauge.
8. Re-torque all bolts as stated in step 12 of the propeller installation section.

REPITCHING: ALTERNATE METHOD

A propeller protractor may be used to set blade pitch. Since some blade models have high performance, round airfoils, the protractor cannot be placed at the blade tip. Mark a straight line from leading edge to trailing edge approximately 3.6" in from each tip and use the protractor to set individual blade angles. Set each blade within ¼ degree to each other

PROPELLER REMOVAL

To remove the propeller, follow the installation instructions in reverse order.

PROPELLER PERFORMANCE

In selecting a propeller, keep in mind that both aircraft and engines of the same model may vary in performance, and that operators may want different performance characteristics. For instance, one person may require a high climb rate while another seeks maximum cruising efficiency.

STANDARD PITCH / NORMAL FLYING

For normal or cross country flying, a propeller that turns up to maximum continuous engine RPM at full throttle level flight will give best all-around performance.

CRUISE PITCH

A cruise propeller will turn 100 to 200 engine RPM less than a standard pitch propeller. While cruise pitches will provide 4-7 mph higher airspeeds at cruise power rpm's, maximum level flight speeds are no better than climb or standard pitches, and the take-off and climb performance will noticeably suffer.

CLIMB PITCH / HIGH ALTITUDE OPERATION For improved take-off and climb performance, use a climb pitch propeller that will turn 100 to 200 engine rpm more than a standard pitch propeller (*Refer to your particular aircraft operating manual for propeller limitations*). Climb pitches will typically reduce flight speeds by 4-7 mph at cruise power RPM's. A climb pitch is also recommended for aircraft operating from high density altitude runways.

NOTE: When pitching propeller for a climb pitch, the propeller WILL overspeed in full throttle level flight. Propeller RPM should never exceed the engine manufacturers recommended maximum RPM. Please refer back to Table 2.

PITCH NOTES AND LIMITATIONS

The faster the airplane, the higher the pitch setting that will be required to keep the engine from over-speeding at Wide Open Throttle (WOT).

While the propeller may be structurally operated at any pitch setting from 0 through 9, the take-off RPM at WOT must meet the aircraft manufacturer's recommended limits to ensure safe flight. Although this propeller model has many pitches available, Propeller RPM should never exceed the engine manufacturers recommended maximum RPM. Please refer back to Table 2.

NOTE: Certain aircraft manufacturers limit the available propeller pitch range to comply with aircraft design regulations.

TACHOMETER INSPECTION

Owing to the exceptionally high stresses that may be generated by particular propeller/engine combinations at certain operating ranges, propeller and aircraft manufacturers have established revolutions per minute (RPM) restrictions and maximum RPM limits for some models. An improperly operating tachometer can cause an engine to exceed the maximum RPM limits or allow operation unknowingly within a restricted RPM band. Since there are no post-manufacture accuracy requirements for engine

tachometers, tachometer inaccuracy could be a direct cause of propeller failure, excessive vibration, or unscheduled maintenance.

Proper tachometer operation and accuracy should always be checked (using the manufacturer's procedure, if available) during normal maintenance intervals. One means of checking the tachometer's accuracy is with a commercial optical unit which is pointed at the rotating propeller.

Table 1: Torque Figures for Specific Bolt Sizes

Bolt Size	Hardware Part Number	Recommended Torque
3/8"	3/8"-24	340-360 in-lbs*

*Torque callout for use with Nord-lock Washers

Notes:

Check mounting bolt torque at least once a year or if vibration occurs.

Hubs use bolts with Nord-Lock washers. Each lock washer works in pairs with the "ramped" sides facing each other. See **Figure 4**.

Table 2: Approved Engine / Propeller/Spacer Combinations and Limitations

Propeller Model	Configuration	Max Diameter (inches)	Min Diameter (inches)	Weight (lbs)	Mass Moment of Inertia (ft-lbs-sec ²)	Approved Engine Models	Limits
3E0M6-C64JE	Tractor	66	62	14	.17	UL390i, is	160HP @ 3300 RPM
						UL520i, is	200HP @ 3300 RPM
3E0M6-C68UE	Tractor	70	66	17	.39	UL390i, is	160HP @ 3250 RPM
						UL520i, is	200HP @ 3250 RPM
3E0K6-C64JE	Tractor	66	62	14	.17	UL390i, is	160HP @ 3300 RPM
						UL520i, is	200HP @ 3300 RPM
3E0K6-C68UE	Tractor	70	66	17	.39	UL390i, is	160HP @ 3250 RPM
						UL520i, is	200HP @ 3250 RPM

WARNING: Propeller blade failure may occur if maximum propeller RPM is exceeded – resulting in severe bodily injury or death!

INSTRUCTIONS FOR CONTINUED AIRWORTHINESS

- Never install a propeller on an aircraft unless it is a model approved for the aircraft and the engine. The service history must be properly documented, and a pre-installation inspection must indicate that the propeller is airworthy.

A visual Inspection is the primary defense against early failure of propellers. When inspecting propellers, it is necessary to use touch and hearing, as well as visual clues. Changes in surface roughness, unusual free play, and odd sounds give hints as to conditions that may affect airworthiness. Feel for roughness and look for texture changes, waviness, and changes in reflection that may signal the removal of protective coatings.

- Do not operate your propeller above the recommended engine RPM. If your propeller has been subjected to an over speed condition of 10% over the maximum rating (example $2700 \times 1.1 = 2970$) for more than 2 minutes, you must perform the **Inspection After Suspected Impact** listed below. **Do not spin your propeller above the engine RPM Limits given in Table 2.**
- Do not operate any aircraft after a propeller has been subjected to an impact without a thorough inspection. See **Inspection After Suspected Impact** below
- The pre-flight inspection is a necessary step in the process of airworthiness maintenance. It should not be merely a superficial look, but a studied review of the condition of everything that might give trouble during the forthcoming flight. *Carefully examine the propeller assembly for looseness, any signs of damage, excessive wear or any other condition that would make the propeller unsafe to operate.* Check the leading edge for cracks and debonds. Externally check the spinner and bulkhead for security, missing fasteners, damage, and cracks. Cracks typically originate from the attachment screws. Check for looseness of the bulkhead. This could be an indication that the mounting bolts are loose and need to be torqued again. If any of the following damage is discovered during the preflight inspection, the propeller must be removed from service until such time as it can be evaluated and repaired by an approved propeller shop:
 - (a) Cracks in the metal hub or bolts
 - (b) Loose metal erosion shield
 - (c) Any crack across or along the blade
 - (d) Blade impact damage with missing

The following will help you operate your propeller safely, keep it looking good and help it to last longer.

- composite material larger than .5 square inches and/or deeper than .025"
- or (e) Obvious damage or wear beyond economical repair.
- This propeller has been static balanced with precision digital equipment. Modern dynamic balancing can be performed with the propeller on the aircraft, and can help reduce vibration and wear of engine accessories and other aircraft components.
- Do not use the propeller as a tow-bar to move your aircraft.
- Apply a good quality automotive paste wax to the blades at least once a year. Avoid liquid waxes.
- Avoid running-up in areas containing loose stones, sand, and gravel, to reduce erosion and/or damage to the leading edges and blades.
- Finish loss off the leading edge is a normal wear item and is dependent on the amount of operation in rain and grit.
- Whenever there is evidence of roughness on operation, check bolt torque on both the clamping and mounting bolts, and check the propeller blades for track. The blades should track within 3/16" of each other at the tip. For new installations, rotating the propeller 180 degrees and reinstalling may help.
- If the bolts are ever over-torqued, they should be replaced immediately.
- **Check bolt torque at least once a year.**
- When the propeller is not in use and exposed to weather, cover it with a waterproof cover to extend the life of the finish.

LIFE LIMITATIONS: None
MAJOR PERIODIC INSPECTION: 2000 HRS
NOTE: There is no specified overhaul time. The propeller parts are removed from service when they can no longer meet the Continued Airworthiness Requirements.

INSPECTIONS

Inspection After Suspected Lightning Strike

-- To be accomplished by an A&P, IA, or repairman.

Any Sensenich composite blade suspected of lightning strike should be inspected and may require repair or replacement. Lightning strikes usually enter a composite blade through the metal erosion shield. If a lightning strike is present, a darkened area and possible pitting, usually in the proximity of the tip, will be noticeable. If a lightning strike is suspected or detected, consider the blade unairworthy. Return the blade to the factory or an **Approved Propeller Repair Station** for further examination.

Inspection After Suspected Impact

-- To be accomplished by an A&P, IA, or repairman.

Propellers that have been involved in a known or suspected static or rotating impact with relatively solid objects (e.g., ground, maintenance stands, runway lights, birds, etc.) or relatively yielding objects (e.g., snow banks, puddles of water, heavy accumulation of slush, etc.) should be inspected for damage before further flight. If the inspection reveals one or more of the following listed indications, the propeller should be removed and sent to an **Approved Propeller Repair Station**.

- (1) A blade that tracks more than 3/16" to the other blades.
- (2) Loose blades in the hub.
- (3) Any noticeable or suspected damage to the blade pitch pins.
- (4) Any diameter reduction (tip damage).
- (5) Visible major damage to the hub that cannot meet the **Minor Hub Repairs** criteria. In particular, inspect for cracks in the bolt holes, counterbores, and barrel cavities which clamp the blades.
- (6) Visible major damage to a blade that cannot meet the **Minor Blade Repairs** criteria.
- (7) Operating changes, such as vibration or abnormal RPM.

NOTE: The bolts should be magnetic particle inspected per ASTM E 1444 or replaced after any propeller strike.

Mandatory Inspections:

- **Annual Inspection -- To be accomplished by an A&P, IA, or repairman.**
 1. Remove spinner dome and examine it for damage, and cracks. If necessary, replace the spinner dome. See **Spinner Repairs** below.
 2. Remove clamp bolts. -- The bolts should be dimensionally checked against one another. Any bolts that exhibit stretching, corrosion or damage such as cracks or nicks are to be replaced.
 3. Remove the hub cover half and set aside.
 4. Remove each blade and inspect blade shanks for any wear, also making sure the blade pitch pin is still tight in the blade shank. A thorough visual inspection is recommended together with a coin tap inspection of each composite blade, including the metal erosion shield on the leading edge (see AC 43-5). No dents in the metal erosion shield should be deeper than 1/8". No dents should puncture the metal erosion shield. There should be no excessive wear on the leading edge. If blade damage is beyond **Minor Blade Repair** instructions below, the blade must either be retired from service or sent to a repair station for evaluation before further service.
 5. Examine the data plate on the shank of each blade. Verify that you are using approved blades for the hub and that everything appears normal. If you are unsure, you can go to <http://www.sensenich.com/> for reference or contact the factory for assistance.
 6. Conditions requiring blade replacement:
 - a) Any hole in hollow blade shell (doesn't apply if a replacement metal erosion shield will cover hole)
 - b) Any crack deeper than .025"
 - c) Any solid tip damage that can't be trimmed off completely with a 2" diameter reduction
 7. Remove the mounting bolts -- The bolts should be dimensionally checked against one another. Any bolts that exhibit stretching, corrosion or damage such as cracks or nicks are to be replaced.

8. Remove the hub mount half and spacer. Inspect both hub halves for corrosion. If necessary, carefully remove any flaked or blistered paint from the hub surface, taking care not to scratch the aluminum surface. If there is any corrosion or damage present, please see **Minor Hub Repair** instructions below.
 9. Remove the rear spinner bulkhead and examine for missing fasteners, damage, and cracks. If damaged, replace the spinner bulkhead.
 10. Inspect the Nord-Lock washers on the inside cam surfaces and outside serrations. Replace washers with excessive wear. Lubricate acceptable washers with a light coating of engine oil or equivalent. **NOTE: Each Nord-Lock washer works in pairs with the “ramped” sides facing each other. See Figure 2.**
 11. Reinstall the assembly per the above installation instructions.
- **2000 Hour Inspection -- To be accomplished by an A&P,IA, or repairman**
 1. Remove spinner dome and examine for damage, and cracks. If necessary, replace the spinner dome. See **Spinner Repairs** below
 2. Remove clamp bolts and special lock washers and retire both sets from service.
 3. Remove the hub cover half and blades. Set aside.
 4. Remove mount bolts and special lock washers and retire from service.
 5. Remove rear spinner bulkhead and examine for damage, and cracks. If necessary, replace the rear bulkhead.
 6. Remove the hub mount half and spacer (if applicable).
 7. Send hub cover half, hub mount half, and blades to an **Approved Propeller Repair Station** for the remaining 2000 hour inspection.
 8. Reinstall propeller repair station approved or new propeller, spacer (if necessary), and spinner per the above installation instructions.

REPAIRS

Minor Blade Repairs

-- To be accomplished by an A&P, IA, or repairman

Minor impact damage, nicks, and gouges in composite material of blade not to exceed .025 depth and or .5 square inches of surface area: Fill with high strength epoxy resin West System 105/206 or equivalent (NOT 5 minute epoxy) thickened with aerospace filler material, such as Colloidal Silica 406, Cabosil, or equivalent. Sand smooth when dry.

Wear and/or roughness of metal erosion shield on blade leading edge: If metal is not worn through, use 220 grit sandpaper or coarse scotch pad to remove roughness or minor pitting, being careful to not grind through the erosion shield. Polish with fine scotch pad or equivalent to remove scratches.

Paint wear on blade:

NOTE, wear is inevitable on the metal erosion shield. The wear rate depends on several factors, including high operating RPM's in rain or sandy areas, FOD on taxiways and runways, etc. Touch up paint using Tempo A150 Flat Black, A152 White, or equivalent. When using touch up paint, keep in mind that paint can cause an out of balance situation so touch up should be kept to a minimum.

Minor Hub Repairs

-- To be accomplished by an A&P, IA, or repairman

Any hub or spacer that would exceed what is depicted in **Figure 6** for minor repair must be retired from service. These dimensions (other than radius) are maximum allowable. Anything less is acceptable. Radius can be greater. A hub can be returned to service with the following limitations:

- No more than two (2) repairs in a single barrel half (where the blade touches the hub) for a total of 8 barrel repairs in one (1) complete hub, as long as the repairs do not touch.
- General hub repairs can be indefinite, both inside and outside, as long as the repairs do not touch.
- No repairs over a previous repair.

- No repairs on the hub mounting flange face.
- No repairs on either flange face of the spacer. Clean the area thoroughly, apply an approved penetrant (**ASTM E 1417** or equivalent), and inspect with a 10X glass before returning to service.

Corrosion – All corrosion must be removed before a hub can be returned to service. Corrosion is considered a repair.

Instructions for removing the damage or corrosion spot:

1. Sand the area with 220 wet-or-dry abrasive paper until all evidence of corrosion is removed. A small motorized grinding tool may be used.
2. Polish the area with 320 grit (or finer) to remove all scratches.
3. Clean the area thoroughly, apply an approved penetrant (**ASTM E 1417** or equivalent), and inspect with a 10X glass. **NOTE:** It is extremely important that all corrosion be completely removed. If cavities reappear during penetrant inspection, the repair operation must be repeated.
4. Remove penetrant from the affected area.

Spinner Repair

-- To be accomplished by an A&P, IA, or repairman

The following repairs are directed toward composite spinners supplied by Sensenich Propeller. For repair of composite spinners not supplied by Sensenich please refer the spinner manufacturers repair instructions.

Minor impact damage, nicks, and gouges in composite material of dome or rear bulkhead not to exceed .025 depth and or .5 square inches of surface area: Fill with high strength epoxy resin West System 105/206 or equivalent (NOT 5 minute epoxy) thickened with aerospace filler material, such as Colloidal Silica 406, Cabosil, or equivalent. Sand smooth when dry.

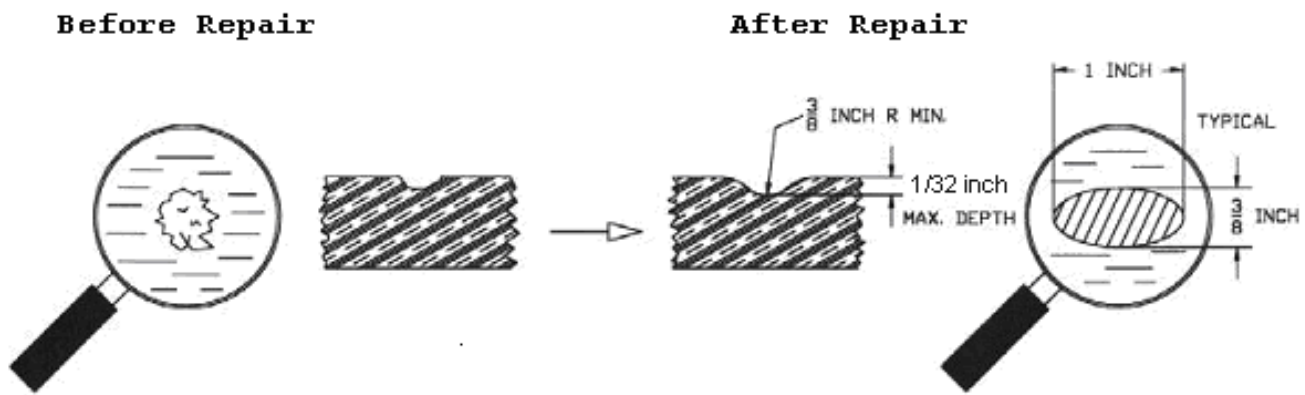

FIGURE 4. MINOR HUB REPAIR LIMITS

LIMITED WARRANTY

We hope you enjoy your new composite propeller. We have worked hard to ensure that your propeller will meet or exceed your expectations for years to come.

We offer a one year limited warranty (the "Warranty Period") on any defect in materials and workmanship.

In the event a unit does not conform to this express warranty during the Warranty Period, Sensenich Composites, Inc. ("Sensenich"), will repair or replace the defective material at its place of business at Plant City, FL USA. Sensenich will decide at its sole discretion which remedy, repair or replacement, it will provide. Any replacement of a unit or a part of a unit during the Warranty Period will not extend the Warranty beyond the original duration. The remedy of repair or replacement is exclusive and does not include the cost of shipping, removal, or installation, all of which are the customer's responsibility.

Procedure for Obtaining Warranty Service

Units or parts that are defective must be shipped prepaid to Sensenich at the address listed on page 1. The unit must be accompanied by a copy of the original (Distributor or Dealer) invoice, a Return Authorization Number (which can be obtained by phoning Sensenich), and a brief description of the defect.

Conditions, Exclusions, and Disclaimers

This limited warranty applies only to units that have been installed, used, and maintained properly in strict accordance with our specifications, instructions, and recommendations. It does not cover units that show abuse, alterations, improper installation, improper maintenance or repair, or improper packaging for shipment; and it does not pertain to damage due to object strike, or excessive blade wear due to operation. Racing use of any kind automatically voids this Warranty. The use of units on or with engines or equipment not approved by Sensenich automatically voids this warranty. For purposes of this limited warranty, "engines or equipment not approved by Sensenich" shall mean engines or

equipment that are not explicitly consistent with all specifications and instructions applicable to that engine or equipment, including, without limitation, those established by the Federal Aviation Administration, those established by the manufacturers of any component parts used in connection with the units, and/or those established by Sensenich. The purchaser has sole responsibility for ensuring that the use of the units is in compliance with all applicable specifications and instructions, and no conduct by Sensenich shall prevent this Warranty from being voided for failure to comply with the instructions or specifications provided by any third-party.

This Limited Warranty is the only warranty provided with respect to covered units, and **THERE ARE NO OTHER WARRANTIES, REPRESENTATIONS, CONDITIONS OR GUARANTEES, EXPRESS OR IMPLIED, WITH RESPECT TO THE COVERED UNITS OR THE MANUFACTURE THEREOF, INCLUDING, WITHOUT LIMITATION, ANY IMPLIED WARRANTIES OF MERCHANTABILITY OR FITNESS FOR A PARTICULAR PURPOSE.**

Repair or replacement of a nonconforming unit or part is the exclusive remedy for breach of this limited warranty, and shall constitute fulfillment of all liabilities of Sensenich to a customer or user, whether based on contract, negligence or otherwise. **IN NO EVENT SHALL SENSENICH BE LIABLE FOR ANY OTHER EXPENSES, CLAIMS OR DAMAGES OF ANY KIND HOWSOEVER CAUSED, INCLUDING (WITHOUT LIMITATION) ANY OTHER PRODUCT REPLACEMENT OR INSTALLATION COSTS AND/OR ANY DIRECT, INDIRECT, CONSEQUENTIAL, INCIDENTAL OR SPECIAL DAMAGES.**

The purchaser of the covered units has read, understood and, by purchasing the units, agrees to be bound by the above terms and conditions.

Some states do not allow the exclusion of incidental or consequential damages, so the above limitations may not apply to you.

This Warranty gives you specific legal rights and you may also have other rights which vary from state to state.

